



Everlong



Design Jens Fager

The length of Everlong can be adjusted to meet the architect's vision and the need for unique solutions. Much design focus has been placed on the harmony in the leg frame's meeting with the seat and the back of the sofa, which also makes the Everlong beautiful as a standalone piece in a room. The Everlong Sofa can also be arranged with backrests back-to-back down the centre.

"Everlong has an honest, clear and open structure that makes it easy to picture in a wide variety of environments. I am very satisfied with the fact that we have used the machines in the best possible ways so that we want to highlight all the details of the metal work instead of covering them up with a fabric."
/Jens Fager

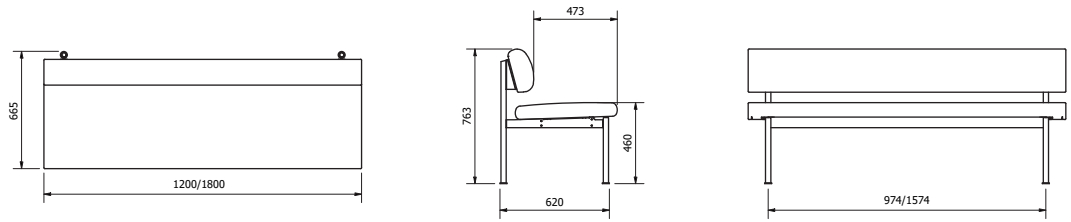

Everlong Sofa 1200/1800

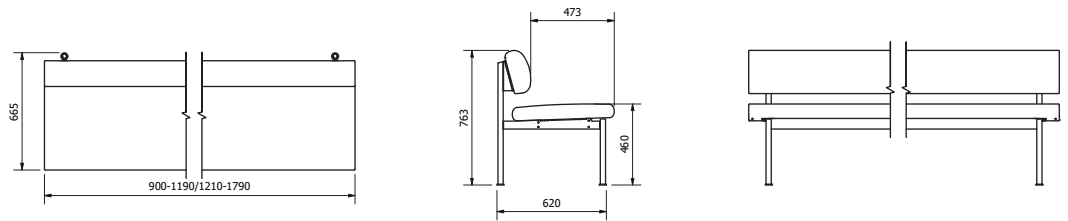

Everlong Sofa Flexi

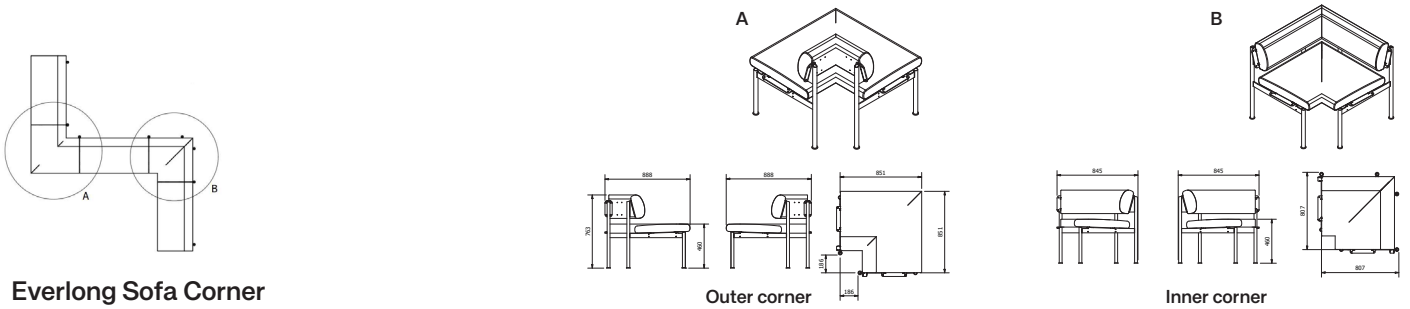

Everlong Sofa Corner

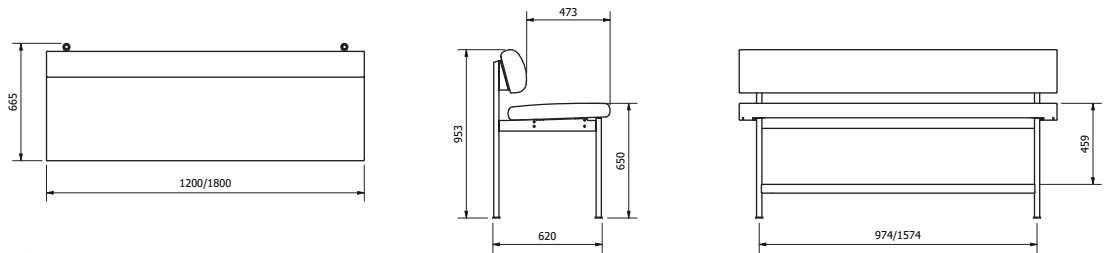

Everlong Sofa High 1200/1800

	Configurable	Assembly	Seat & Backrest	Stand	Certificate
Everlong Sofa 1200/1800 Everlong Sofa Flexi Everlong Sofa Corner Everlong Sofa High 1200/1800	Fabric & finish Configure at my.edsbyn.com	Knockdown	Upholstered. Foam density 55kg/m3. Flame-retardant RG55280.	Powder coated steel	

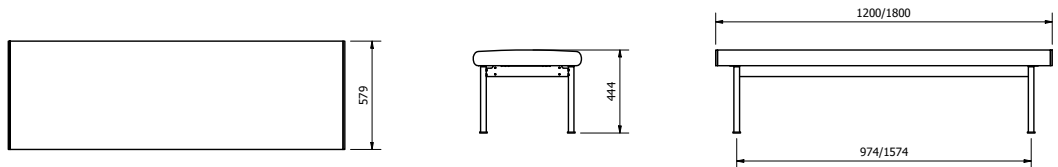

Everlong Bench 1200/1800

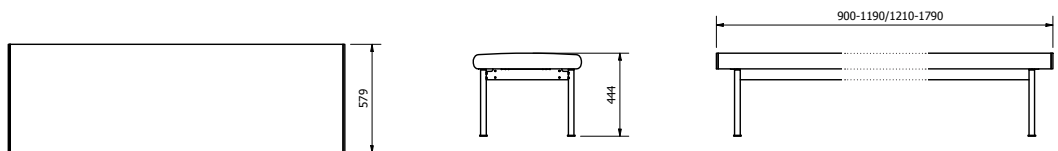

Everlong Bench Flexi

	Configurable	Assembly	Seat & Backrest	Stand	Certificate
Everlong Bench 1200/1800 Everlong Bench Flexi	Fabric & finish Configure at my.edsbyn.com	Knockdown	Upholstered. Foam density 55kg/m ³ . Flame-retardant RG55280.	Powder coated steel	

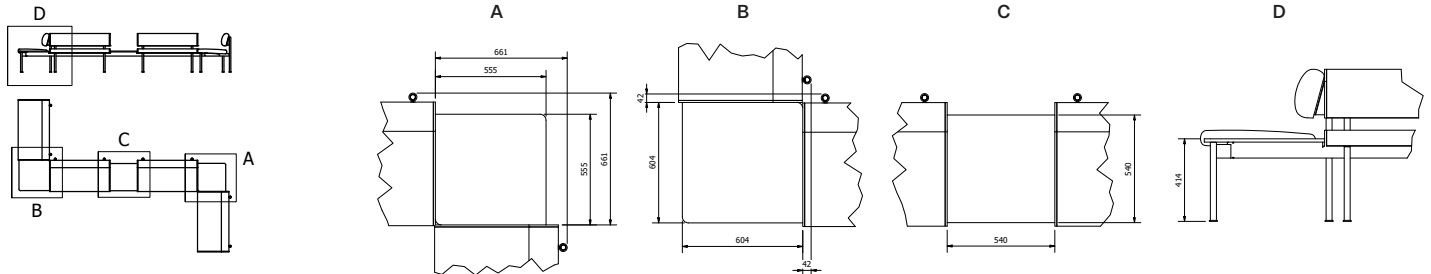
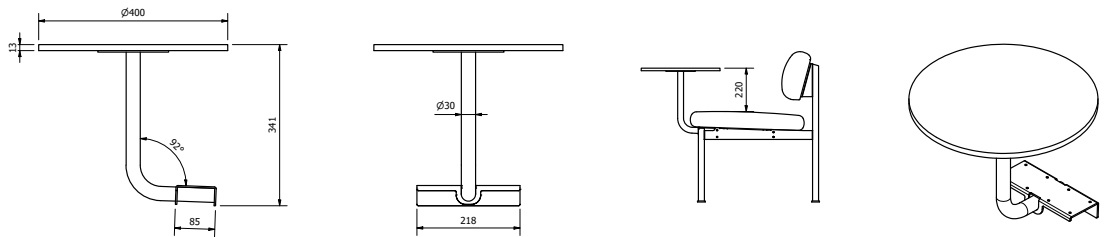

Table Corner/Between

Inner corner

Outer corner

Between



Floating Table

	Configurable	Assembly	Table top	Stand	Certificate
Table Corner/Between Floating Table *	Table top and bracket Configure at my.edsbyn.com	Assembled on site	Veneer, HPL, Desktop	Powder coated steel	

* The Floating Table is not available for assembly on the bench.



Climate-Smart

All materials and surface treatments are approved for public environments with high wear and tear, and will last for many years without the need for maintenance.

Certified according to Möbelfakta

Technical quality standards for sustainability, stability, safety and for surface resistance. Environmental standards for materials and products.

ISO Certified Production

Edsbyverken is certified according to quality and environmental management standards ISO 9001 and ISO 14001.



Color & Trim

Customized furniture with extensive configuration possibilities is our specialty. Edsbyn's selected palette, Color & Trim, showcases a small selection of the color schemes offered for standard orders.

All materials are carefully selected with environmental sustainability as our top priority. All finishes offered in Color & Trim are sustainable and suitable for environments with heavy daily wear and tear.

Explore the complete selection of materials and colors available for you to choose from at my.edsbyn.com



Edsbyn Factory

The secret of our success is the ability to change and adapt. What began in 1899 as a small carpentry, grew in to be one of the largest furniture factories in the Nordics. Between 1934 and 1984, we produced wooden skis for the Ministry of Defence, Olympic gold medal winners, and families. From the waste material, we manufactured pin-back chairs, which became well-known and cherished in Swedish homes.

As one of Sweden's oldest furniture companies, with roots in Edsbyn, we can proudly say that we have played a part in making the label Swedish Design synonymous with good form and function.